

Series EA Electric Actuators Low Torque, Medium Torque, and Spring Return

For use with VB-7000 and VB-9000 Series valve bodies from Barber-Colman and many other commercially available rotary shaft valve bodies with crank arm and HVAC and combustion air dampers.

Used for two position, floating, and proportional control of dampers and valves in industrial applications. Typical applications are heat treat furnaces, ovens, heat recovery systems, water or oil cooling systems.

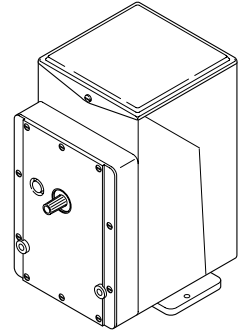

Features

- Proportional Actuators with Built-in Feedback Potentiometers
- Spring Return and Non-spring Return Models Available
- 24 Vac, 120 Vac and 240 Vac Models Available
- Die Cast Housings with Four 1/2" conduit Openings
- Oil Immersed Motor and Gear Train
- SPDT Auxiliary Switch Standard

1 Introduction

Actuators of this family may be easily identified by referring to the part number shown on the nameplate on top of the gear case. The date of manufacture stamped on the case is a four digit number. The first two represent the week of the year, the last two represent the year.

These actuators meet the requirements of both damper control and valve control applications where it is desirable to move the load in either direction, or to stop it at any point in the stroke. All models contain feedback slidewires for true position-proportional control.

Actuators are shipped without mounting hardware or linkage. In damper applications, crank arms, connectors, link rods and mounting brackets will be required. In valve applications, valve bodies and AV type linkages will be required.

Before installing the actuator, look for bent or broken parts or oil leaks. Actuators should be connected to a power supply to check operation prior to installation.

Low/Medium Torque Actuators

The actuator should be operated in ambient temperature of -40°F to 136°F (-40°C to 58°C). Input is 28 watts and 50 VA. All standard actuators include a 100 ohm feedback potentiometer. The active winding of the potentiometer is either 180 or 90 angular degrees, as defined by the model number code selection.

2 Specifications

Actuator Inputs

Input Control Signals: Refer to the actuator part number for input control signal capability of your specific actuator model.

Floating Control : Requires one SPDT switch with floating position (center off) rated at 0.9 amps @ 24 Vac, or two SPST switches rated at 0.9 amps @ 24 Vac.

Two Position: SPDT requires snap acting switch rated a 0.9 amps @ 24 Vac (no center off position) SPST can be used with certain spring return actuators. Switch must be rated to handle actuator power requirements.

Current/Voltage/

Potentiometer: Requires Model 658 or Model 659 position converter. See part number for ranges.

Connections: Coded screw terminals.

Actuator Outputs

Power Requirements: Refer to the actuator part number to determine power requirements.

Torque: Refer to the actuator part number to determine torque rating.

Nominal Damper Area:	Actuator Torque <u>lb.-in (N-m)</u>	Parallel Blade <u>sq. ft. (m²)</u>	Opposed Blade <u>sq. ft. (m²)</u>
	50 (5.6)	28 (2.6)	36 (3.3)
	60 (6.8)	33 (3.1)	42 (3.9)
	130 (14.7)	72 (6.7)	92 (8.5)
	220 (24.9)	122 (11.3)	157 (14.6)
	450 (40.9)	250 (23.2)	322 (29.9)

Note: Damper ratings are nominal and based on standard (not low leakage) at 1" (25.4 mm) W. C. differential pressure across the damper in the closed position and 2,000 FPM (ten m/s) velocity in the full open position.

Stroke: Refer to the actuator part number to determine degrees of rotation.

Auxiliary Switch:	<u>Electrical Rating</u>	<u>120 Vac</u>	<u>240 Vac</u>
	Running	5.8 amps	2.9 amps
	Locked Rotor	34.8 amps	17.4 amps
	Non-inductive	12	6

Environment

Ambient Temperature Limits: Shipping and storage: -40°F to 160°F (-40°C to 71°C)
Operating: -40°F to 136°F (-40°C to 58°C)

Humidity: 5 to 95% RH, non-condensing

Protection: NEMA 1. NEMA 4 for actuators with code 37 in field 7,8.

Low/Medium Torque Actuators

3 Model Number

Model E A - - - -

Field No. 1 2 3 4 5 6 7 8 9 10 11 12 13 14 15

Fields 1, 2. Model Series

EA - Base Model

Fields 3, 4. Base Model

	Travel Limits	Time (seconds)	Torque (lbs/in; N-m)
--	---------------	----------------	----------------------

Low Torque; Non-Spring Return

21*-	90°	12	50; 5.6
22*-	180°	25	50; 5.6
23 -	90°	12	50; 5.6
24 -	180°	25	50; 5.6

Low Torque; Spring Return

41 -	90°	45	50; 5.6 (cw)
42 -	180°	90	50; 5.6 (cw)
44 -	180°	90	50; 5.6 (ccw)

Medium Torque; Non-Spring Return

51 -	90°	12 (adj)	60; 6.8
52 -	180°	25 (adj)	60; 6.8
53 -	90°	12	60; 6.8
54 -	180°	25	60; 6.8
55 -	90°	40 (adj)	220; 24.9
56 -	180°	80 (adj)	220; 24.9
57 -	90°	40	220; 24.9
58 -	180°	80	220; 24.9
60 -	90°	65	450; 50.9
61 -	180°	130	450; 50.9

Fields 5, 6. Input

Note: Model 658A is a current to position converter; model 659A is a resistance to position converter.

Input Signal Converter Model

00 -	Contact	
11 -	4 to 20 mAdc	658A-00001
12 -	4 to 12 mAdc	658A-00002
13 -	12 to 20 mAdc	658A-00003
14 -	2 to 12 mAdc	658A-00004
15 -	2 to 7 mAdc	658A-00005
16 -	7 to 12 mAdc	658A-00006
19 -	Other, Special	658A-00008-000-X-XX**
31 -	Slidewire	659A-00000

The following codes are rain tight input converters mounted to the series EA. To order the series EA weather resistant, you must select cover option 37 (fields 7, 8).

Rain Tight Converters:

21 -	4 to 20 mAdc	658A-00011
22 -	4 to 12 mAdc	658A-00012
23 -	12 to 20 mAdc	658A-00013
24 -	2 to 12 mAdc	658A-00014
25 -	2 to 7 mAdc	658A-00015
26 -	7 to 12 mAdc	658A-00016
29 -	Other, Special	658A-00018-000-X-XX**
41 -	Slidewire	659A-00010

**Consult factory.

Fields 7, 8. Options

00 - None

37 - NEMA 4 weather resistant cover. This option must be included if rain tight converter is ordered.

Non-Spring Return Actuators Only

Options 01 through 07 cannot be combined with rain tight converters.

01 - Two auxiliary SPDT switches

02 - Four auxiliary SPDT switches

03 - Rear shaft

04 - 100 Ω rear slidewire

05 - 100 Ω rear slidewire with two switches

06 - 1000 Ω rear slidewire

07 - 1000 Ω rear slidewire with two switches

31 - One 100 Ω rear slidewire, weather resistant

32 - Two 100 Ω rear slidewires, weather resistant

33 - Three 100 Ω rear slidewires, weather resistant

Field 9. Motor Voltage/Frequency

0 - 120 Vac 60 Hz

1 - 120 Vac 50 Hz (n/a with EA52, 54)

3 - 240 Vac 60 Hz (n/a with EA21, 23, 24, 41)

4 - 240 Vac 50 Hz (n/a with EA21, 23, 41, 53, 58)

5 - 24 Vac 60 Hz (n/a with EA21, 23, 41, 51, 53, 54 or 658A or 659A)

Fields 10, 11. Transformer

Non-Spring Return Actuators Only

00 - None

01 - Built-in 120 – 24 Vac (n/a with 658A or 659A)

02 - Built-in 240 – 24 Vac (n/a with 658A or 659A)

Field 12. Feedback Slidewire

0 - 100 Ω

1 - 135 Ω

2 - 500 Ω

3 - 1000 Ω

Fields 13, 14, 15. Special

0-00 - None

*Note: Models EA21 and EA22 do not include end of travel limit switches or an auxiliary switch.

Low/Medium Torque Actuators

4 Installation



CAUTION!

Disconnect the power supply (line power) before installation to prevent injury and equipment damage!

Make all connections in accordance with the wiring diagram and in accordance with national and local electrical codes.
Use copper conductors only!



CAUTION!

Do not exceed the ratings of the devices!

Avoid locations where excessive moisture, corrosive fumes, or vibration is present!

Note: If, after wiring is completed, the actuator shaft does not turn in the desired direction, invert leads to terminals 2 & 3, and to 7 & 8 of the actuator terminal block!

Make all electrical connections in accordance with the job wiring diagram and in compliance with national and electrical codes. Power wire selection is shown below. When multiple 24 Vac actuators are powered from the same transformer, the actuators must be in phase; connect the same transformer lead to the "G" terminal on all actuators and the same transformer lead to the "H" terminals on all actuators.

<u>Power</u>	<u>AWG</u>	<u>Maximum Run</u>
24 Vac	14	115' (35 m)
24 Vac	12	180' (55 m)
24 Vac	10	285' (87 m)
120 Vac	14	810' (247 m)
120 Vac	12	1275' (388 m)
120 Vac	10	2040' (622 m)
240 Vac	14	3340' (1018 m)

Line voltage units include a barrier which separates the line voltage terminals from the low voltage. On line voltage actuators, Class I circuits must be used for connections to power terminals (L1, L2) and auxiliary switch terminals (1, 5, 6) On 24 Vac actuators, Class II circuits may be used for connections to power terminals (G, H) and auxiliary switch terminals (1, 5, 6) if the auxiliary switch terminals are connected to 24 Vac or are not being used. Class II circuits may be used in the low voltage compartment to make connections to control circuit terminals (X, 2, 3) and potentiometer terminals (4, 7, 8).

Damper Mounting Do not mount low torque actuators upside down. Do not mount adjustable speed units with output shaft up, or with speed adjustment screw pointing up. Other actuators may be mounted in any position, although the upright position is recommended.

Low/Medium Torque Actuators

Damper Linkage Assembly



CAUTION!

The damper must not be mechanically stopped before the actuator has reached its electrical limit of travel or permanent damage can occur to the actuator!

1. During installation of the linkage assembly, place the primary controller in the manual mode to drive output high or low. Or, control the actuator manually as shown in Figure 11 on page 13.
2. Mount the actuator in an appropriate position near the damper. Actuator must be linked to the damper so that it can complete its full stroke. Damper rod that is too long is not rigid enough for good control and damper rod that is too short makes it difficult to adjust the linkage.
3. Attach a ball joint (linkage connector) to the actuator and damper crank arms at the correct position in the crank arm slot depending on the application. See Figure 1. A 180° rotation damper actuator provides the best close-off at the end of stroke and the best controllability (turn down ratio).
4. Typically the damper should be linked for an angular rotation of less than 90° that provides the required flow (typically 60°). This provides the optimum close-off and controllability.

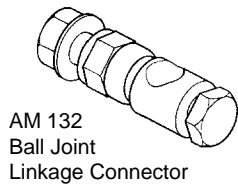

Ball Joint Position, 180° Rotation Actuators

Damper Rotation	Actuator Arm	Damper Arm
90°	2-1/4" (1)	3-1/8" (2)
80°	2"	3-1/8" (2)
70°	1-3/4"	3"
60°	1-1/2"	3"

Ball Joint Position, 90° Rotation Actuators

Actuator Arm	Damper Arm
3-1/8" (2)	3-1/8" (2)
2-3/4"	3"
2-1/2"	3"
2-1/4" (1)	3-1/8" (2)

(1) = Prick point. (2) = End of slot.

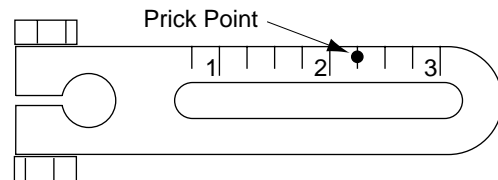

Figure 1. Slot provides adjustment from 7/8" to 3-1/8".

5. With the actuator powered, manually position the actuator to the position that is required for the closed position of the damper. Rotate the damper to its mid-stroke. Install the crank arms on the damper shaft and the actuator so that crank arms are parallel. The crank arm on damper shaft should be secured to the shaft and the crank arm on the actuator should be free to rotate.
6. Attach the push rod to the ball joint connectors on both crank arms and tighten the ball joint screws only thumb tight.

Low/Medium Torque Actuators

7. Rotate by hand the crank arm on the actuator to drive the linkage and the damper shaft through its full stroke to ensure proper damper action.
8. Return the damper to its closed position and tighten to secure the actuator crank arm.
9. While pushing the damper closed, tighten the ball joint screws to secure the damper rod.
10. Run the actuator back and forth through its full stroke and check for proper damper and linkage operation. Adjust linkage if required.



CAUTION!

**If the crank arm does not provide proper travel, reset the linkage.
Never attempt to turn the actuator shaft with a wrench or crank;
this may damage the actuator!**

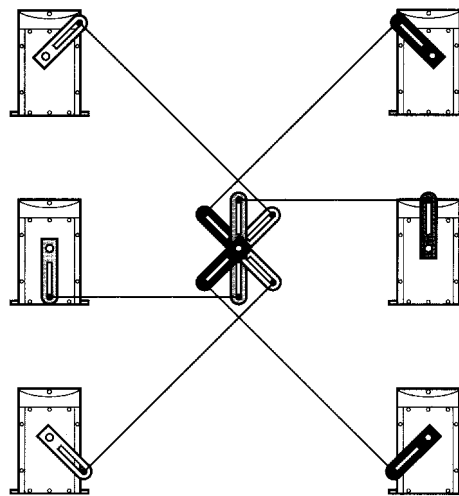

Figure 2. Typical Actuator Mounting Positions.

Low/Medium Torque Actuators

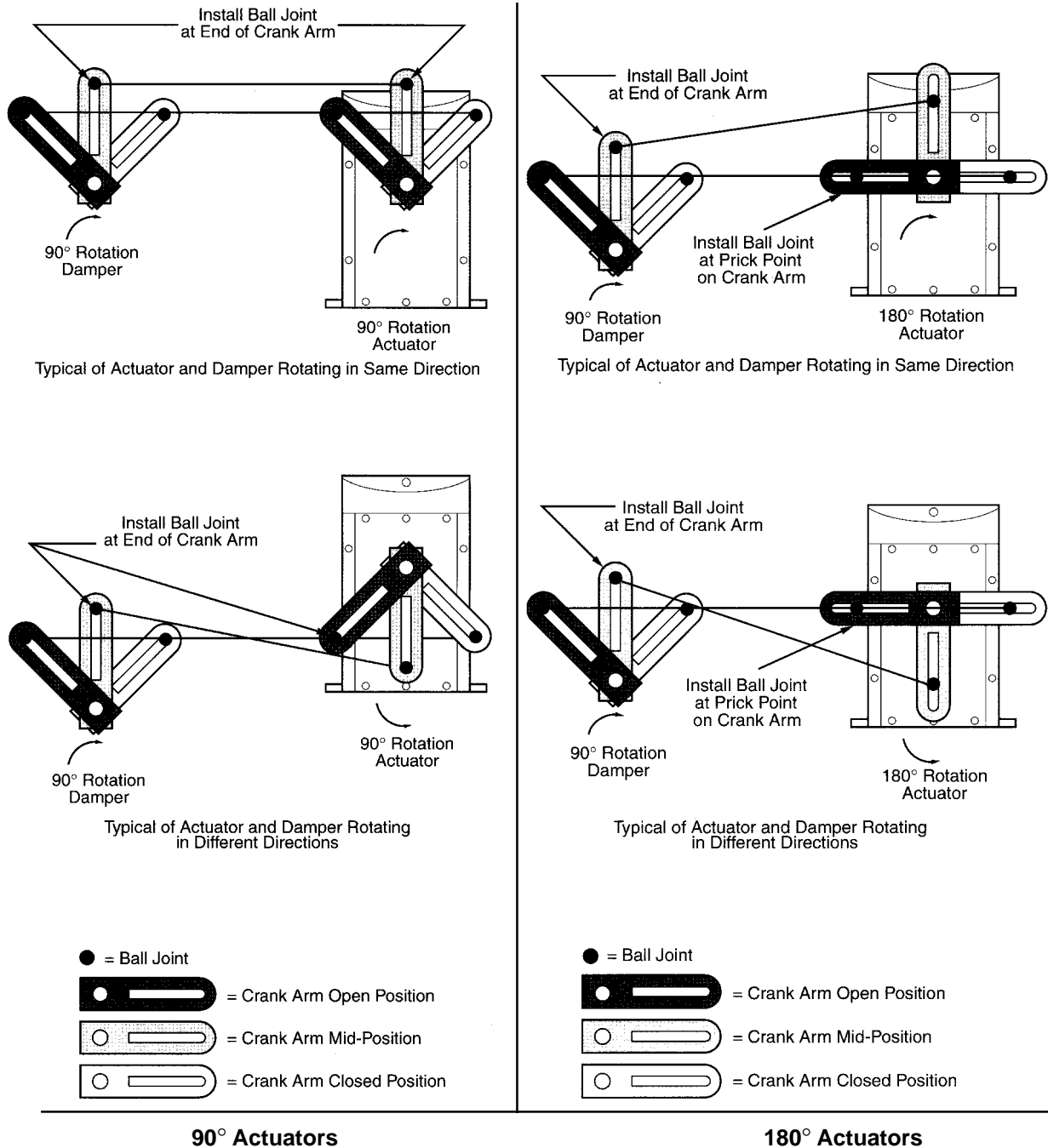

Figure 3. Typical Damper Linking.

Note: If, after wiring is completed, the actuator shaft does not turn in the desired direction, invert leads to terminals 2 & 3, and to 7 & 8 of the actuator terminal block!

Low/Medium Torque Actuators

Valve Installation Install all globe type valves with pressure under seat except where a flow direction arrow on the valve body indicates otherwise. For best control, three way valve applications should be designed to use mixing valves.

Preferred mounting is with valve stem upright, but can be mounted in other positions. Valve assemblies using an adjustable speed actuator should never be mounted upside down or with front (indicator side) of actuator facing up.

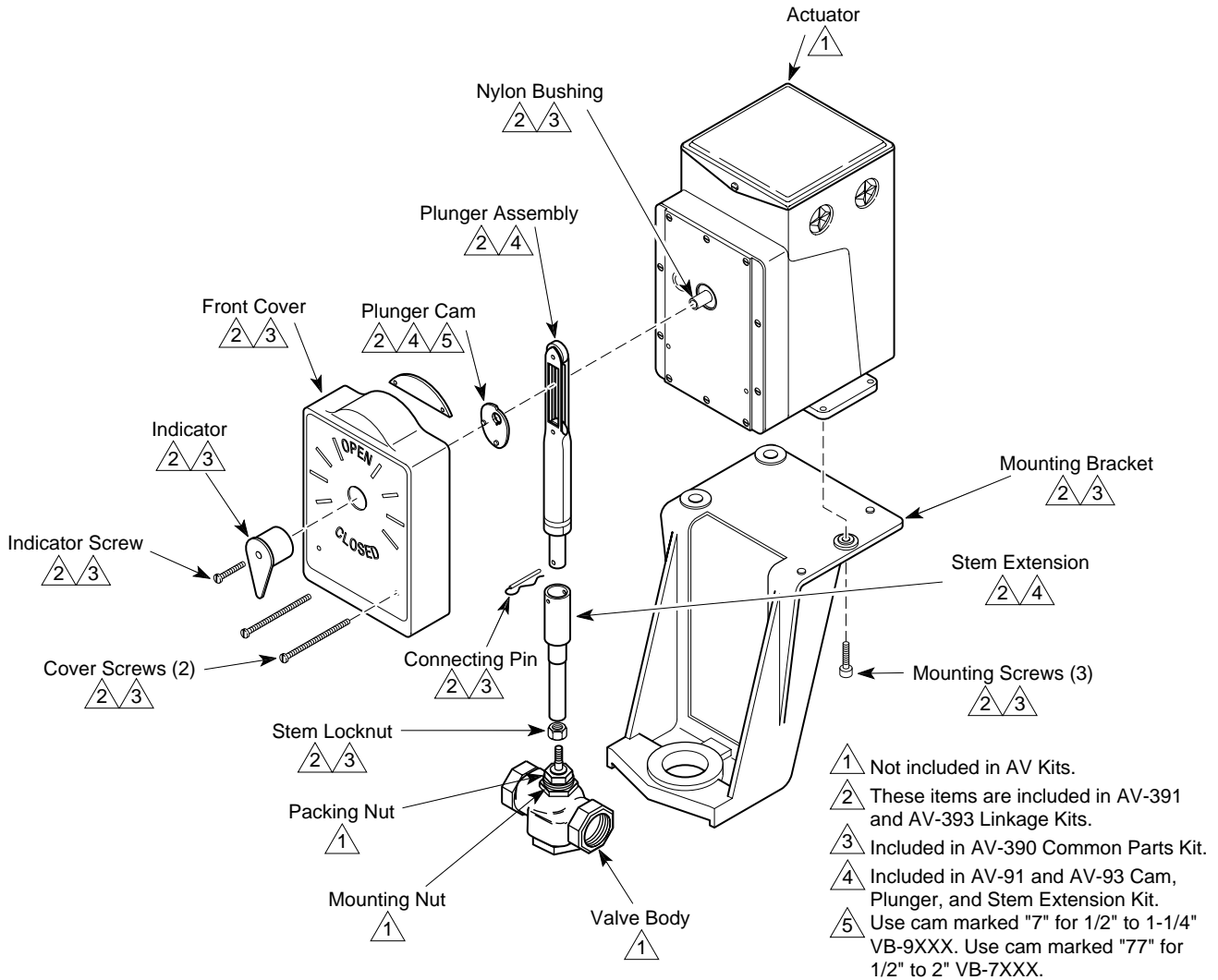

Figure 4. Typical Valve/Actuator Assembly Components.

Note: Information for linkage kits to Barber-Colman Series VB-7000 and VB-9000 valves is available as accessory information in document 1322-IN-007-0-XX. Linkage to other valve bodies of similar stem stroke and collar size may be achieved by adjustment of these linkage kits.

Valves are normally factory assembled and tested prior to shipment, but when necessary to assemble the valve, proceed as follows:

Low/Medium Torque Actuators

- 1) Apply power to L1 and L2 (G and H for 24 Vac). Install a jumper from terminal 2 to X. Run actuator shaft to clockwise end of rotation (short tooth of output shaft at 9 o'clock). Remove jumper when position is obtained.
- 2) Slip Nylon bushing on actuator shaft.
- 3) Place plunger cam in plunger assembly with point of cam down, then slip the cam on the actuator shaft. *It is imperative that the point of the cam be downward to assure proper correlation between actuator direction of rotation and the valve closed position.*
- 4) Screw stem lock nut and stem extension down to bottom of threads on stem.
- 5) Remove the valve packing nut and bracket nut from valve and place bracket on valve body. Replace the valve bracket nut, packing nut, and tighten. Place actuator on mounting bracket while at the same time aligning plunger assembly over the stem extension. Fasten actuator to the mounting bracket with the three 1/4-20 screws provided.
- 6) Adjust plunger spring compression: stem length should be such that the disc seats before the actuator reaches the end of its closing stroke. Remainder of travel is taken up in plunger spring compression and should amount to approximately 1/16". This provides pressure on disc in closed position and tends to compensate for disc and seat wear. On three way valves, spring compression should be provided on both upper and lower seats.

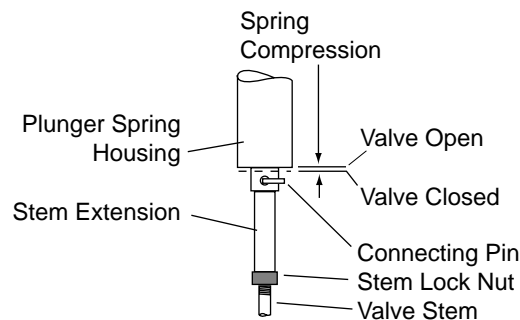

Figure 5. Stem/Plunger

- 7) Push down on the valve stem to make sure the disc is on the valve seat.
- 8) Turn the stem extension up into the bottom of the plunger assembly until hole line up with the holes in the plunger assembly. Then turn the stem extension two complete turns further in the same direction.
- 9) Run actuator partly open by placing a jumper between terminals 3 and X and raise valve stem until the connecting pin can be inserted through the plunger and stem extension holes together. Tighten stem lock nut against stem extension.
- 10) Place front cover over plunger assembly and fasten to the actuator with the self-tapping screws provided. Install position indicator to end of actuator shaft by aligning the key in the indicator with the notch in the plunger arm. Then fasten in place with the provided screw.

Checkout After the system has been installed, the following checks for proper operation may be used:

- 1) Set controller to call for process variable decrease. Check actuator rotation to insure correct direction.
- 2) Set controller to call for process variable increase. Check actuator rotation to insure correct direction.

Low/Medium Torque Actuators

Looking at the front of the actuator (the shaft facing you), a 4 mAdc input signal will cause the actuator to rotate CW (closed between terminals 2 and X). With a 20 mAdc input signal, the actuator will rotate CCW (closed between 3 and X)

5 Run/Adjust

Actuator variations are shown in Figure 6. Line voltage proportional actuators without optional transformers are designed to be driven directly from position-proportioning temperature controllers, contacts from manual position switches, or current or resistance to position converters.

Line voltage proportional actuators can be purchased with a built-in transformer to supply low voltage to external circuits for a paralleling relay or position indicator.

All actuators in this series utilize a reversible shaded pole motor with two shading coils. The field of the motor is typically energized continuously. Shorting either shading winding (X-2 or X-3) will cause the motor to run in the appropriate direction. In spring return models, interruption of power to the field will cause the motor to drive to the selected end of stroke (fully CW or CCW, depending on model)

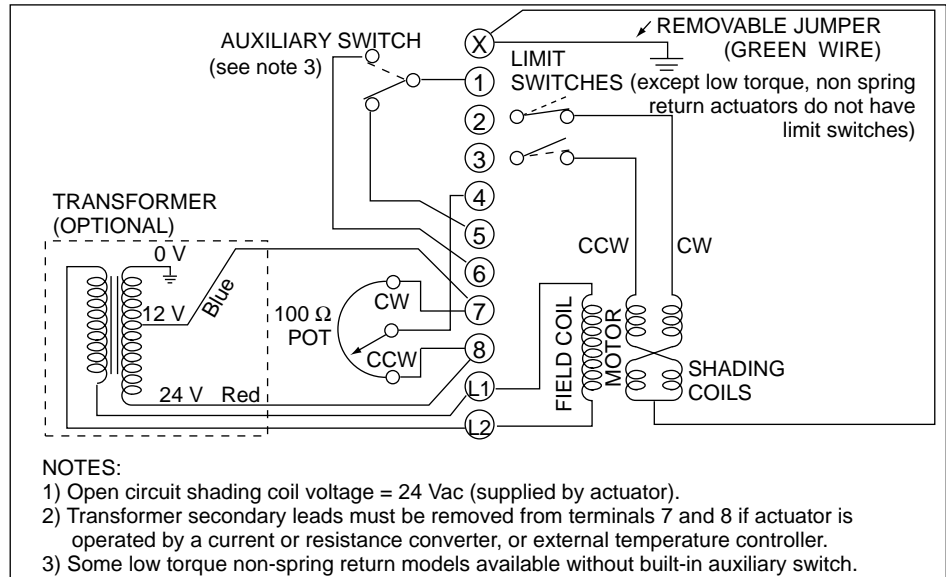

Figure 6. Internal Wiring

5.1 End of Travel Limit Switch Adjustment

You can adjust the high end (CCW) of travel limit switch by inserting a screwdriver through the access hole in the terminal block plate to the notched cam near the front of the actuator. Turn the cam clockwise – as seen from the front of the actuator – to increase the length of rotation; turn the cam counter-clockwise to decrease. Each click of the cam represents about 3°

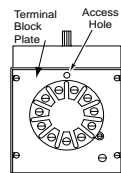

Figure 7. Top View

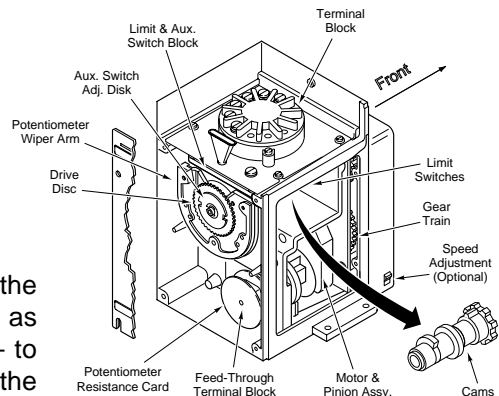

Figure 8. Exploded View

Low/Medium Torque Actuators

change. Attempting to adjust for more than the nominal rotation rating in degrees will cause the slidewire (potentiometer) wiper to exceed its travel end limits and affect calibration. Different slidewires are furnished for 90° or 180° models.

The clockwise, low end of travel limit switch (middle switch) is fixed and cannot be field adjusted. If the actuator terminal block plate is ever removed, it is imperative that it be replaced in its original position. If this is not done, the clockwise limit switch setting may change slightly as the switches themselves are anchored to the underside of the terminal block plate. Rotation is stopped when the switch cam follower rides up a lobe of its cam.

On valve actuators, it is important that the plunger cam and indicator point straight down at the clockwise end of the actuator rotation. Minor adjustments in the clockwise limit switch can be made to accomplish this by loosening the top plate and shifting it slightly in the screw slots until the proper location is attained.

5.2 Auxiliary Switch Adjustment

The adjustable, built-in SPDT auxiliary switch is actuated by the cam nearest the back of the actuator. It is factory set to switch near the CW end of the actuator rotation. Terminal 1 of the common of the switch is made to terminal 5 from the CCW end of rotation until the switch point, then terminal 1 is made to terminal 6 for the rest of the stroke.

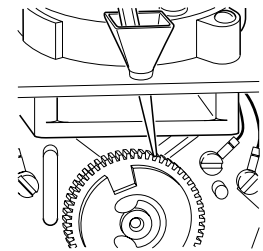

Figure 9. Adjusting Auxiliary Switch

To adjust the switch point of the auxiliary switch, follow the steps shown below.

Note: If, through mis-adjustment or damage, actuator travel has been increased beyond 180°, the auxiliary switch may, depending on its switch point, operate twice in a given stroke.

1. Remove the top cover of the actuator.
2. The actuator should be powered and positioned to desired point in actuator stroke for the auxiliary switch to operate.
3. The access hole for the auxiliary switch adjustment is located in the terminal plate of the actuator, near terminal 1.



CAUTION!

Disconnect the power to the actuator at the power terminals (H and G or L1 and L2) plus the auxiliary switch terminals (1, 5, 6) More than one disconnect may be required!

5. Turning the cam CW (as seen from the front of the actuator) increases the length of actuator rotation. Each click of the cam represents about 3° change in actuator rotation.
6. After adjusting the cam, check the rotation by shorting actuator terminal X to terminal 3 to drive the actuator to its new CCW limit setting.
7. If the travel is not what is desired, repeat steps 2 through 6 until desired results are obtained.

Low/Medium Torque Actuators

5.3 Speed Adjustment (Optional)

You can adjust the timing speed of some models of medium torque actuators with the slotted adjustment screw on the lower left side of the front housing. Turn the screw clockwise to decrease the speed. Total timing can be decreased to about 1/10 the normal. For example, an actuator whose timing is normally 25 seconds to travel full open can be increased to approximately 250 seconds. Take care not to turn the adjustment screw too far clockwise as this will stall, but not damage, the actuator. If stalling occurs, turn the screw counter-clockwise until the motor resumes operation. The total adjustment is normally 3-1/2 turns.

6 Maintenance

Minimum maintenance is required since the motor and gear train are submerged in oil for continuous lubrication and cooling. If necessary to refill the actuator with oil (refill capacity 1 to 1-1/4 pints), always use immersion oil which is available in quart containers (BYZP-195). For best performance, oil level – with actuator upright – should be up to the edge of the oil fill hole which is located in the front case of the actuator. In this case, lay the actuator on its back when refilling with oil.

7 External Wiring

A primary controller with current output driving either a Model 658 Current to Position Converter, or a retransmitting slidewire driving a Model 659 Resistance to Position converter can be used to control an EA Series Actuator as illustrated in Figures 13 and 14. Also, see wiring table on last page.

Terminal X is the shading coils common connection and is normally connected to case ground with a green wire jumper. This jumper may be removed if the control instrument requires that the input connections to the electric actuator be isolated from ground. Normally, the jumper should remain connected.

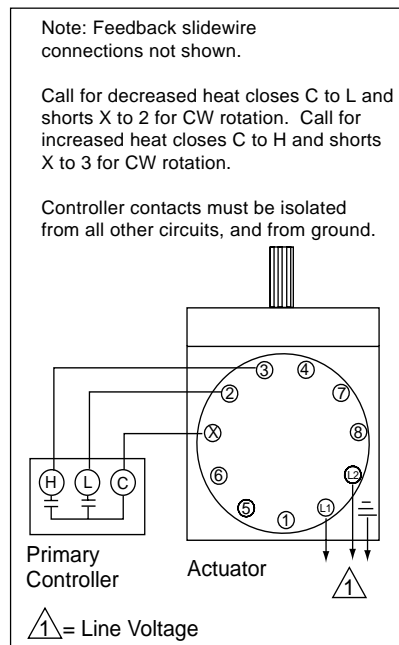

Figure 10. Position Control

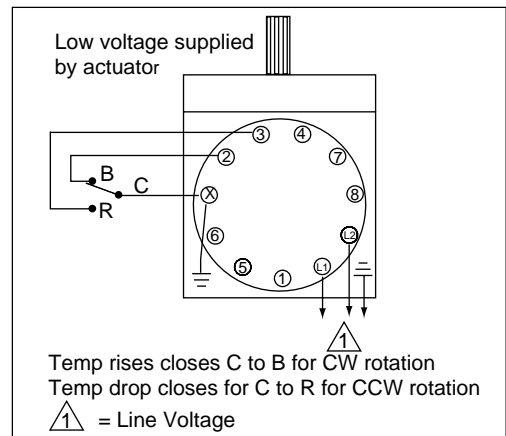

Figure 11. Two Position Control by an On/Off Temperature Controller or Thermostat.

Low/Medium Torque Actuators

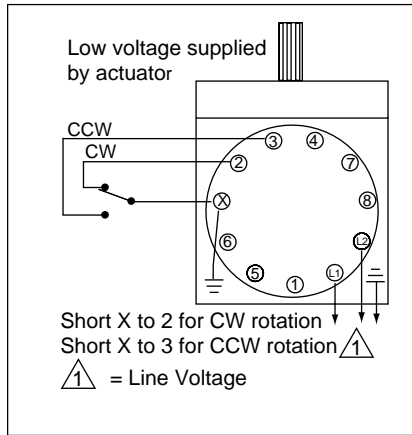

Figure 12. Manual Control of a Proportional Actuator

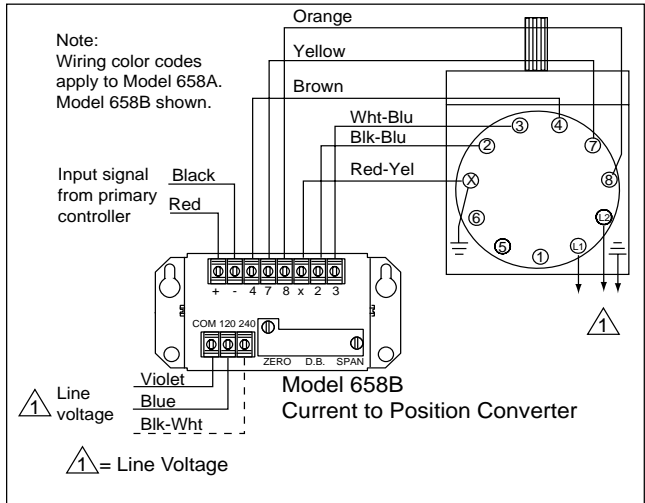

Figure 13. Current Input Control

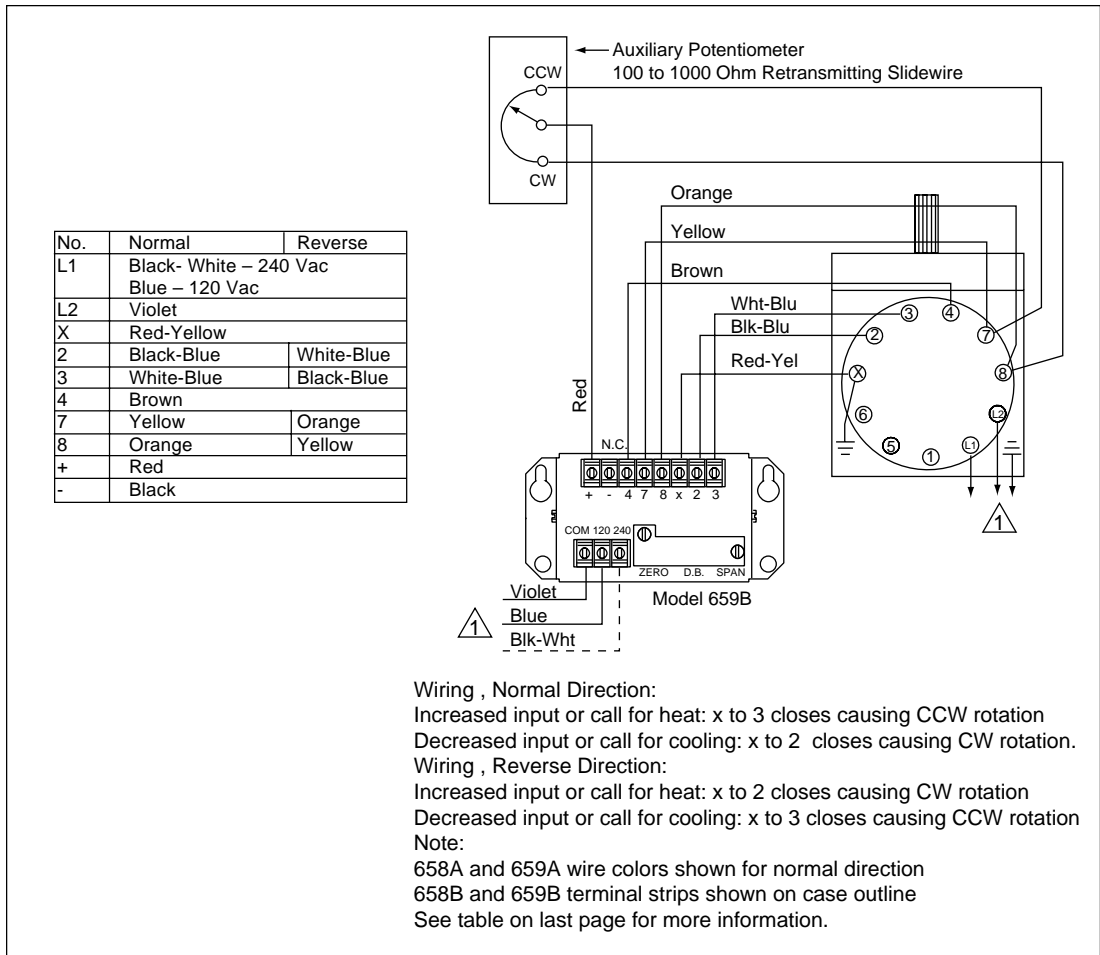

Figure 14. Slidewire Resistance Input Control

Low/Medium Torque Actuators

8 Mounting Dimensions

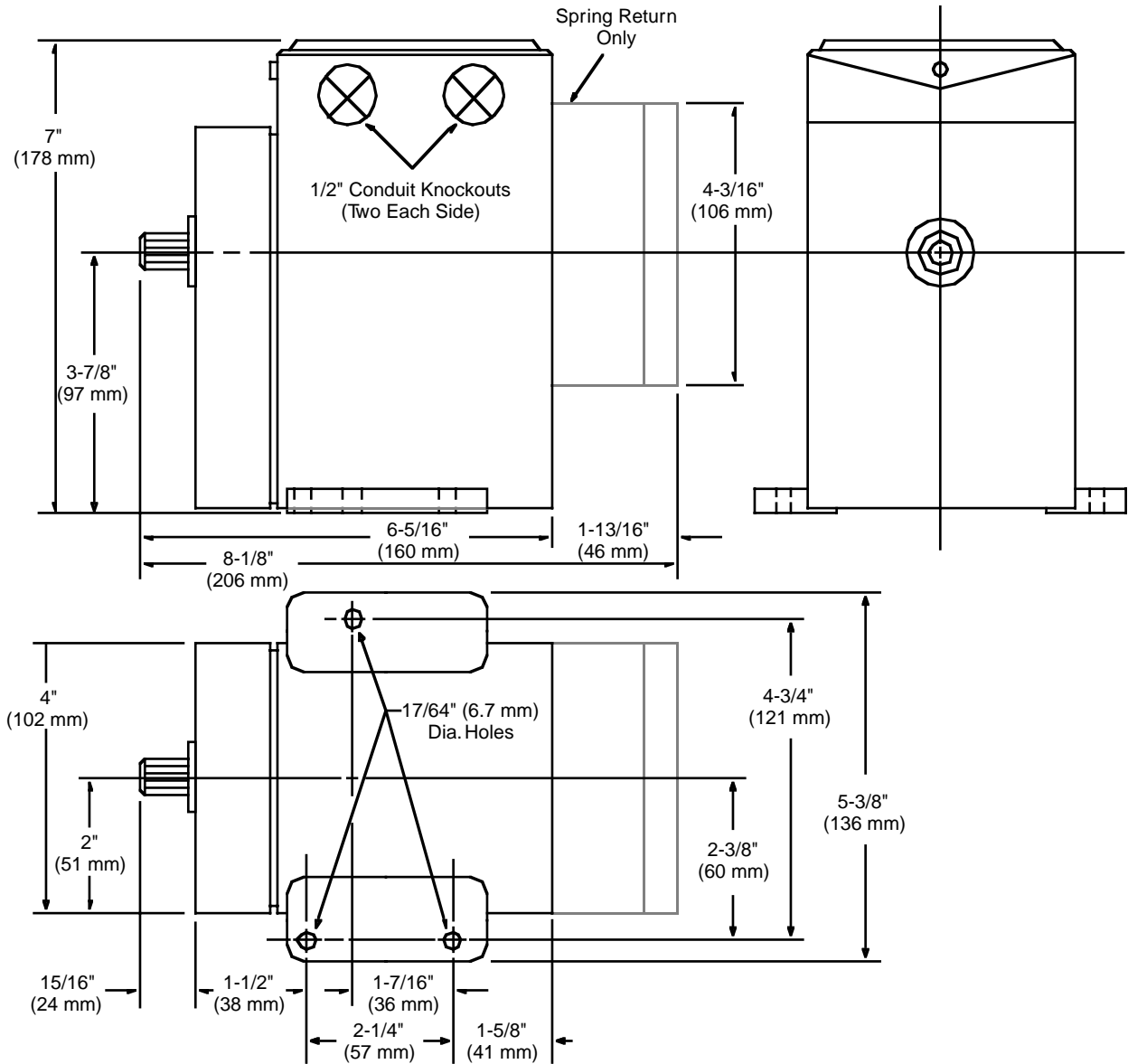

Figure 15. Mounting Dimensions, EA Actuator

Low/Medium Torque Actuators

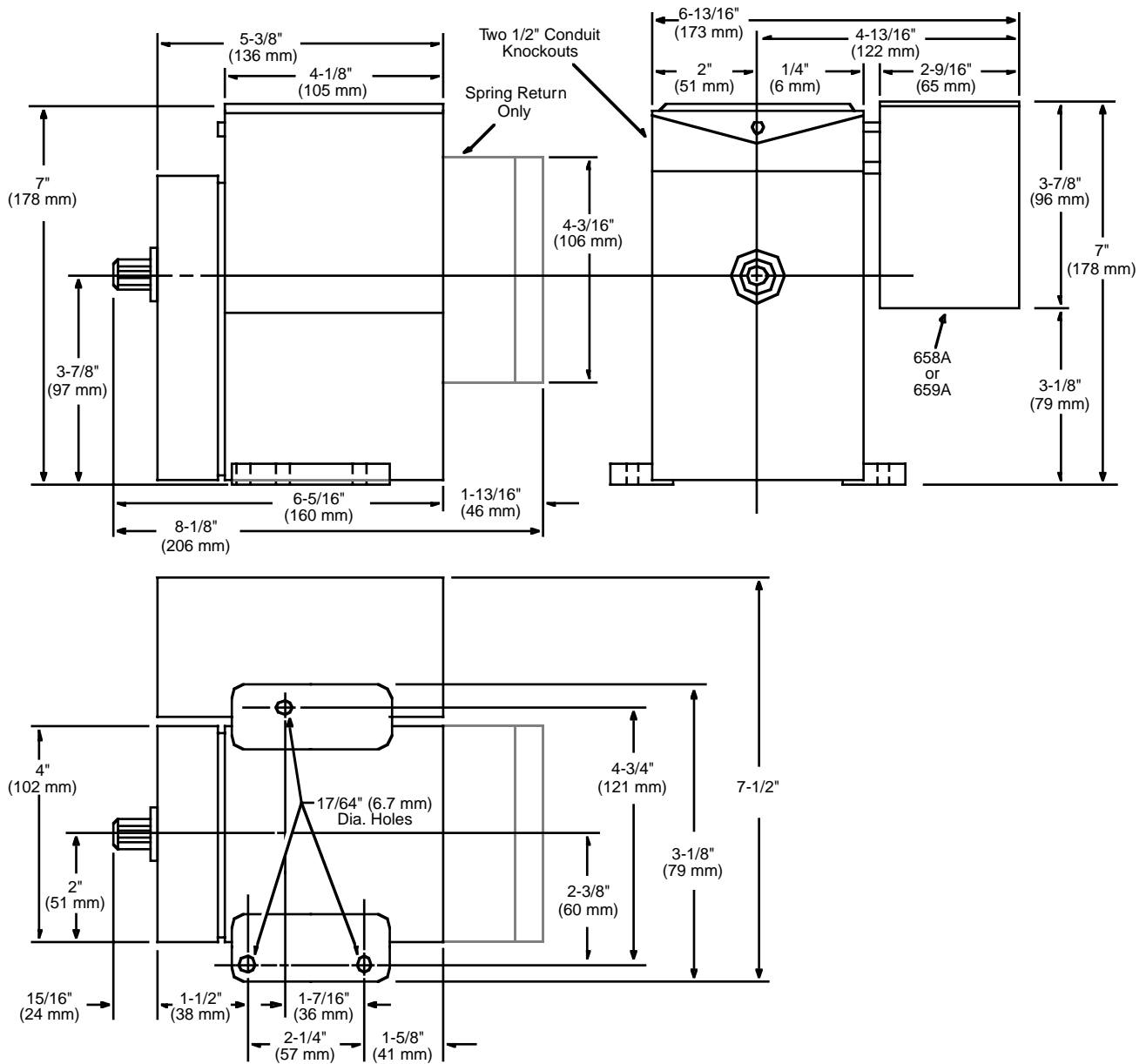

Figure 16. Mounting Dimensions, EA Actuator with Converter

Current Converter and Resistance Converter Wiring

Model 658 Using the connections shown in the table below, increasing input causes CCW actuator rotation. To reverse actuator rotation, invert leads at actuator terminals 7 & 8, and 2 & 3.

A special option (65 or 66 in fields 14, 15 of the converter model code) is available on Model 658A that provides an extra (white) wire for activation of the purge option used on a burner control. A dry contact closure between the purge wire and the input + (red) wire will drive the actuator full open to provide 100% flow for air purge of a gas burner. Converters with special option 65 are wired for mounting on the left side of the actuator; converters with option 66 are wired for the right side of the actuator.

Model 659 Using the connections shown in the table below, CW rotation of slidewire (or potentiometer) causes CW actuator rotation. To reverse actuator rotation, invert leads A & B

Note: All references to direction of rotation are determined by looking at actuator output shaft.

Converter		Actuator Terminal Numbers
Terminal Number Model 658/659B	Wire Color Model 658/659A	Low, Medium Torque (EA2X, 4X, 5X, 6X)
4	Brown	4
7	Yellow	7
8	Orange	8
X	Red-Yellow	X
2	Black-Blue	2
3	White-Blue	3
COM	Violet	L2
120 Vac	Blue	L1
240 Vac	Black-White	L1 (see motor voltage rating)
+	Red	Model 658: Connect to positive output terminal of controller. (See purge option below). Model 659: Connect to wiper of remote slidewire or potentiometer (See below)
-	Black	Model 658: Connect to negative output terminal of controller. Model 659: Not connected.
n/a	White	Model 658A: Purge option:(special 65 or 66), dry contact that closes to red lead.
Remote Slidewire or Potentiometer (with Model 659 Resistance Converter)		



InstruCon, Inc.
3415 Precision Drive,
Rockford, IL 61109

815-874-2000
815-874-2211 Fax

<http://www.instrucon.com/actuators>