

Model EA31 Electric Actuator Medium Torque, Non-Spring Return

For use with VB-7000 and VB-9000 Series valve bodies from Barber-Colman and many other commercially available rotary shaft valve bodies with crank arm and HVAC and combustion air dampers.

Used for two position control of dampers and valves in industrial applications that do not require return to normal position upon power interruption.

Features

- 24 Vac, 120 Vac and 240 Vac Models Available
- Die Cast Housings with Four 1/2" Conduit Openings
- Oil Immersed Motor and Gear Train
- SPDT Auxiliary Switch Standard

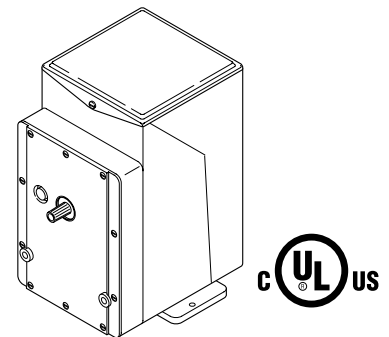

1. Introduction

This uni-directional actuator (clockwise rotation) requires a three wire control circuit; SPDT snap-acting switch or its equivalent – such as a thermostat, pressure switch, or relay. A built-in, cam operated, snap acting, adjustable auxiliary switch is standard. It is factory set to make at mid-stroke. One contact closes at end of stroke; other contact closes at end of next stroke.

The actuator is shipped without mounting hardware or linkage. In damper applications, crank arms, connectors, link rods, and mounting brackets will be required. In valve applications, a valve body and AV type linkage will be required.

Before installing the actuator, check for bent or broken parts or oil leaks. Actuators may be connected to power supply to check operation prior to installation.

Medium Torque Actuator

Theory of Operation

The actuator gear-train assembly is built with limit switches to stop output shaft rotation at the end of 180° CW travel. Valve linkage, purchased separately, assembled to the actuator has a cam operated plunger which transforms the rotary motion of the actuator output shaft to linear motion to operate the valve stem.

The actuator requires an SPDT switching action in the controller, e.g., thermostat, pressure switch, or relay. "R" contact is made on a call for heat; "B" contact is made on a call for less heat; and "C" terminal is common.

"R" terminal on the actuator (assume a valve) is a switch that starts to open the valve; "B" starts to close the valve; and, "C" is the limit switch. Auxiliary cam operated switches are available for the operation of additional valves, actuators, relays, etc.

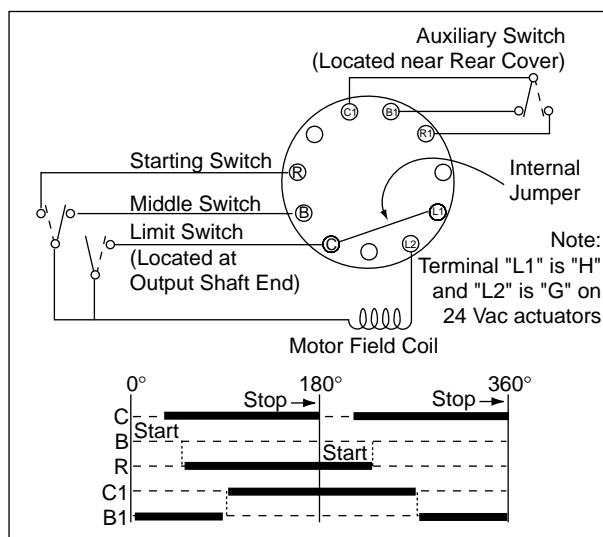

Figure 1. Internal Wiring and Cam Chart

2. Specifications

Control Action:	3 wire, SPDT snap acting switch provided by thermostat, pressure switch or relay	
Connections:	Coded screw terminals	
Shaft Rotation:	Unidirectional CW 180° each time power is applied	
Auxiliary Switch:	Adjustable SPDT standard. Factory set to make or break at mid-stroke	
	<u>Type</u>	<u>120 Vac</u> <u>240 Vac</u>
	Running	5.8 Amps 2.9 Amps
	Locked Rotor	34.8 Amps 17.4 Amps
	Non-inductive	12 Amps 6 Amps
	Two or four SPDT auxiliary switches optional. Amp ratings same as above.	
	Maximum total load not to exceed 2000 VA.	
Ambient Temperature:	-40 to 136°F (-40 to 58°C)	
Humidity:	5 to 95% rh, non-condensing	
Case:	Die cast aluminum with two 1/2" conduit knockouts each side	
Mounting:	Damper: any position; Valve: upright with actuator above center line of valve body. Allow 6" (152 mm) clearance above wiring compartment	
Dimensions:	7" H x 5-3/8" W x 6-5/16" D (178 mm x 137 mm x 160 mm)	

Medium Torque Actuator

3. Model Number

Model E A 3 1 - 0 0 **- 0 0 0 - 0 - 0 0**
 Field No. 1 2 3 4 5 6 7 8 9 10 11 12 13 14 15

Fields 1 through 4. Model

	Travel Limits	Time (seconds)	Torque (lbs/in; N-m)
EA31-	180°	30	220; 24.9

Fields 5, 6. Reserved

Fields 7, 8. Options

- 00 - None
- 01 - Two auxiliary SPDT switches
- 02 - Four auxiliary SPDT switches
- 37 - Weather resistant housing; no aux. switches

Field 9. Motor Voltage/Frequency

- 0 - 120 Vac 60 Hz
- 3 - 240 Vac 60 Hz
- 5 - 24 Vac 60 Hz

Fields 10 through 15. Reserved

4. Installation

Preferred mounting for the actuator is in the upright position but other positions are acceptable. Allow six inches clearance above the actuator wiring compartment. Actuator may be used in damper and valve control applications. Figure 2 illustrates linkage operating arm through a 90° arc.

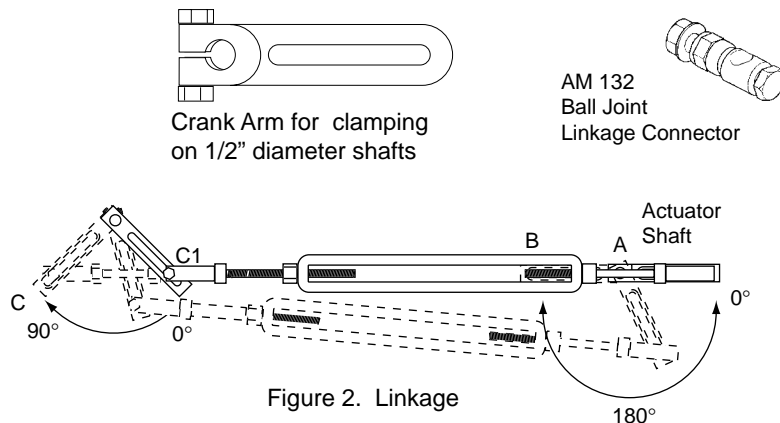

Figure 2. Linkage

Damper Installation

To fasten damper linkage, proceed as follows:

- 1) Fasten linkage connector and end of damper crank arm.
- 2) Fasten linkage connector at punch mark on actuator crank arm (about .707 of the radius).
- 3) Move damper to normal position and clamp connecting link to connectors.
- 4) Check adjustment for proper operation by running actuator and driven shaft between limits of travel.

CAUTION!

If crank arm does not provide proper travel, reset connecting link in linkage connector. Never attempt to turn the actuator shaft with a wrench or crank. This may damage the gears.

Medium Torque Actuator

Valve Installation

Install all globe type valves with pressure under seat. Refer to flow arrow on body or piping information on valve body tag.

Note: Information for linkage kits to Barber-Colman Series VB-7000 and VB-9000 valves is available as accessory information in document 1322-IN-007-0-XX. Linkage to other valve bodies of similar stem stroke and collar size may be achieved by adjustment of these linkage kits.

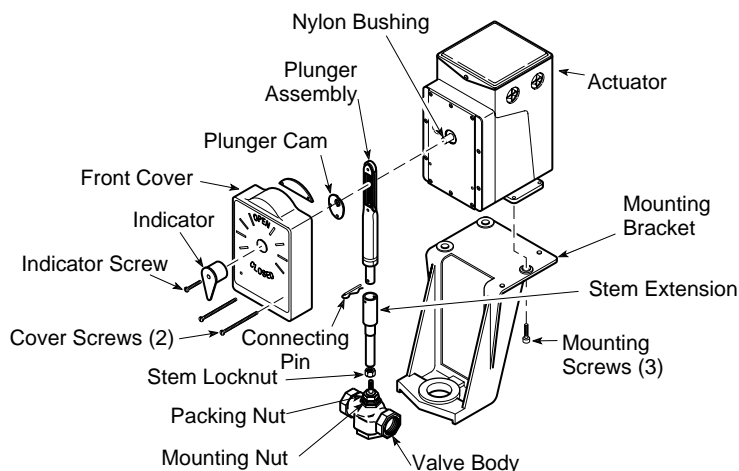

Figure 3. Typical Valve/Actuator Assembly Components

5. Wiring

CAUTIONS!



Disconnect the power supply (line power) before installation to prevent injury and equipment damage!



Make all connections in accordance with the wiring diagram and in accordance with national and local electrical codes.



Use copper conductors only!



Do not exceed the ratings of the devices!



Avoid locations where excessive moisture, corrosive fumes, or vibration is present!

Power wire selection is shown below. When multiple 24 Vac actuators are powered from the same transformer, the actuators must be in phase; connect the same transformer lead to the "G" terminal on all actuators and the same transformer lead to the "H" terminals on all actuators.

Power	AWG	Maximum Run
24 Vac	14	115' (35 m)
24 Vac	12	180' (55 m)
24 Vac	10	285' (87 m)
120 Vac	14	810' (247 m)
120 Vac	12	1275' (388 m)
120 Vac	10	2040' (622 m)
240 Vac	14	3340' (1018 m)

Medium Torque Actuator

Class I circuits must be used for connections to the control and power terminals (L1, L2, R, B, and C) on line voltage actuators. Class II circuits may be used for connections to the control and power terminals (H, G, R, B and C) on 24 Vac actuators. Connections to the auxiliary switch terminals (R1, B1, C1) may be per Class II circuits except when the switch is used on line voltage applications in which case Class I circuit must be used. When powering actuators from a common transformer, the G terminals must all connect to the same side to prevent transformer damage.

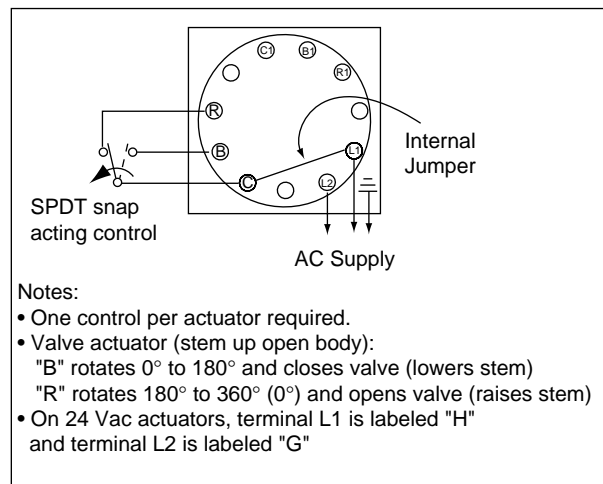

Figure 4. External Wiring for Heating Application

Checkout

After the entire system has been installed, the following checks for proper operation must be made:

- 1) Be sure the system is powered, and on.
- 2) Turn thermostat to call for cool. Actuator should rotate clockwise from 0° to 180°, turning off the heating media. View actuator from output shaft end (front).
- 3) Turn thermostat to call for heat. Actuator should rotate from 180° to 360° (also 0°), and turn on heating media.
- 4) If the room temperature varies excessively, check for these causes:
 - Thermostat in wrong location for proper sensing
 - Improper air distribution
 - Thermostat not properly calibrated
 - Thermostat has dirty contacts
 - Thermostat cover has slots blocked
 - Heating media unavailable
 - Heating media will not shut off

Medium Torque Actuator

6. Internal Auxiliary Switch Adjustment

The adjustable built-in SPDT auxiliary switch is actuated by the cam nearest the back of the actuator. Although it can be adjusted to operate at any point in the actuator rotation, it is factory set to operate at approximately mid-stroke.

To set the operating point of the internal auxiliary switch:

- 1) Insert a screwdriver through the opening in the top plate directly behind the terminal block plate, and engage the gear-like plastic disk.
- 2) Adjust the switch to operate the 0° (360°) end of actuator travel by turning the disk clockwise. Each “click” of the switch adjustment disk represents approximately three angular degrees change in the operating point.

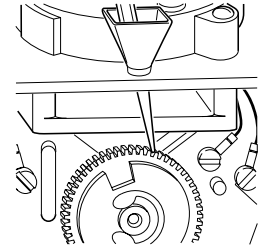

Figure 5. Adjusting Auxiliary Switch

7. Maintenance

Minimum maintenance is required since the motor and gear train are submerged in oil for continuous lubrication and cooling. If necessary to refill the actuator with oil (refill capacity 1 to 1-1/4 pints), always use immersion oil which is available in quart containers (BYZP-195). For best performance, oil level – with actuator upright – should be up to the edge of the oil fill hole which is located in the front case of the actuator. In this case, lay the actuator on its back when refilling with oil.

Medium Torque Actuator

8. Mounting Dimensions

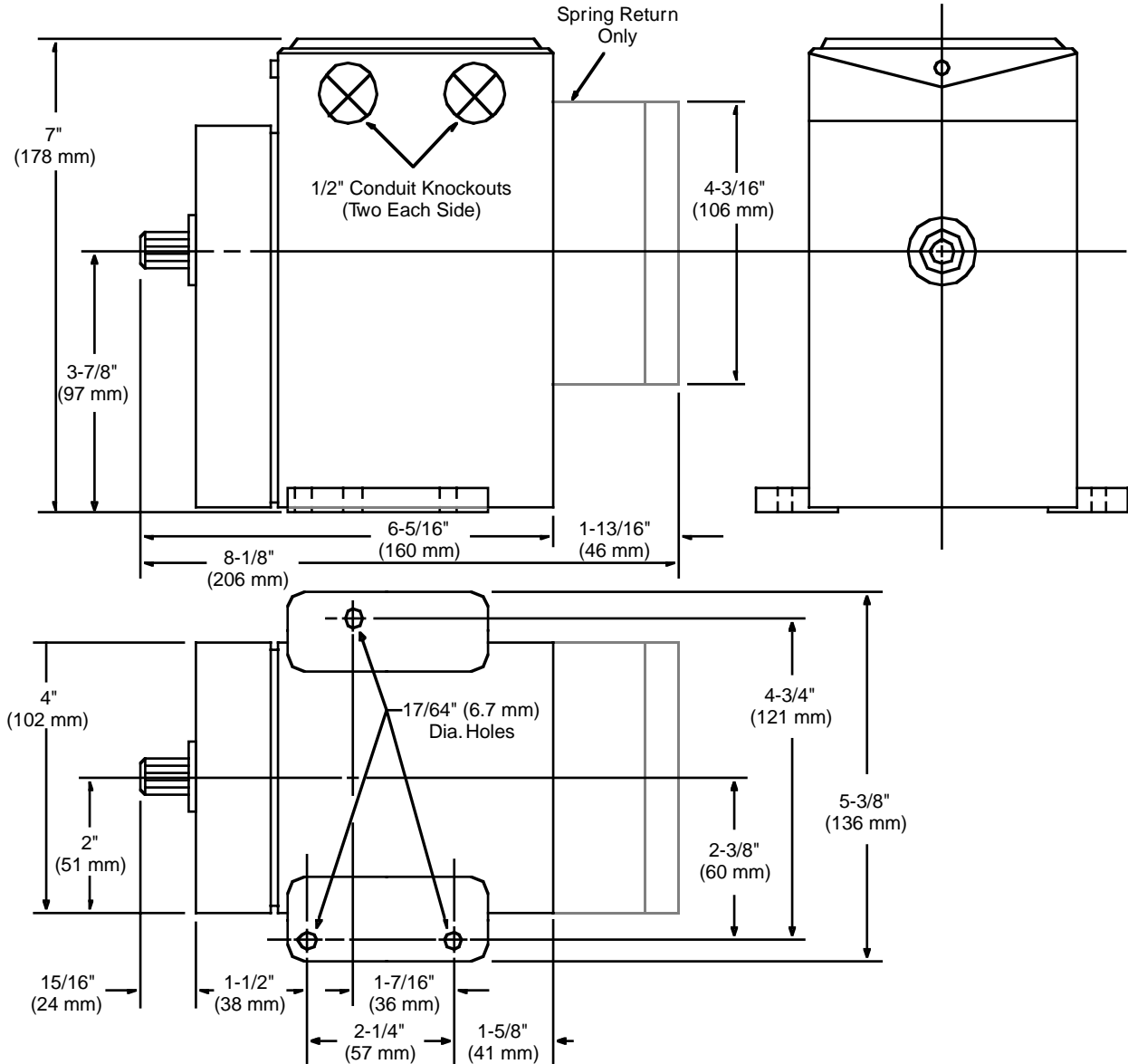

Figure 6. Mounting Dimensions



InstruCon, Inc.
3415 Precision Drive,
Rockford, IL 61109

815-874-2000
815-874-2211 Fax

<http://www.instrucon.com/actuators>